

NLF

The innovative fermentation system.

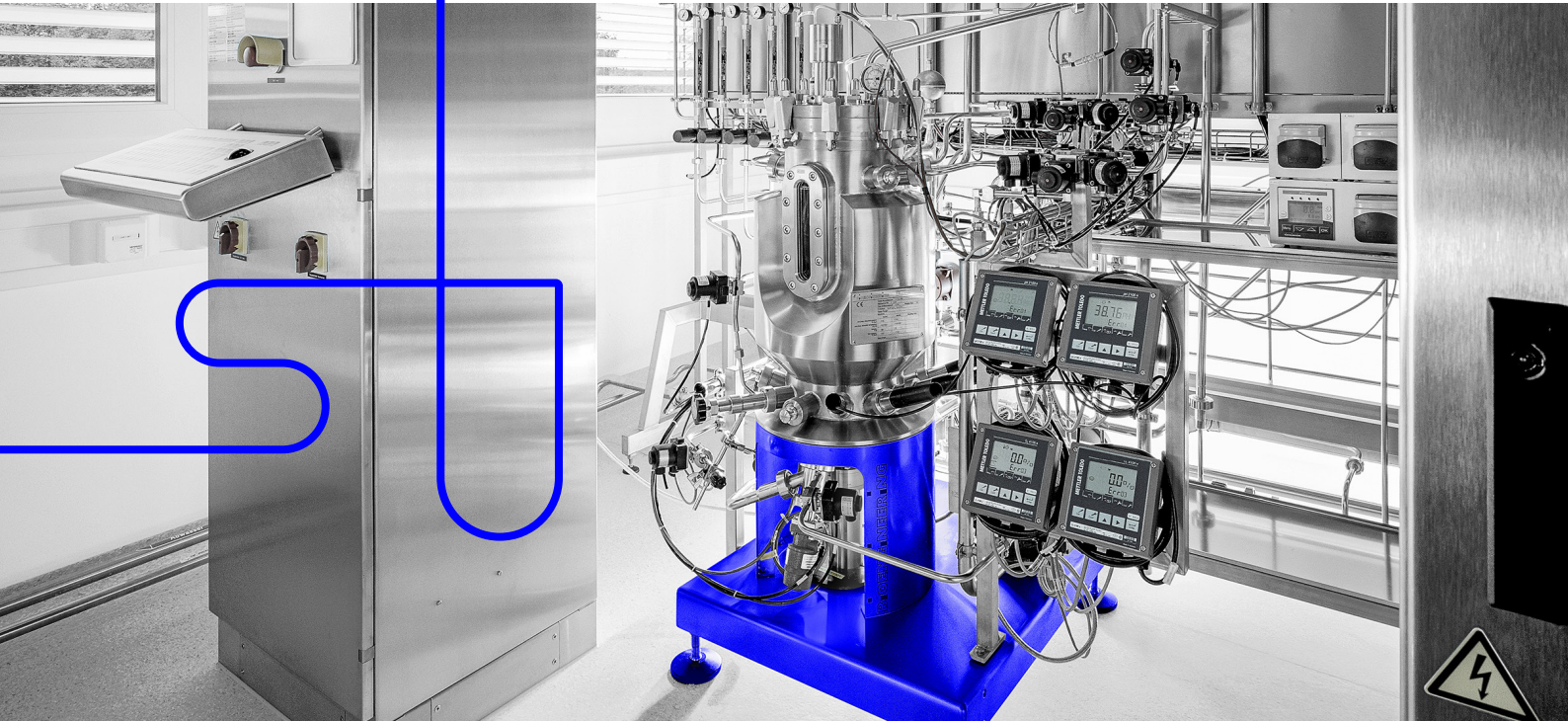

Fermentation technology for your individual needs

The NLF series offers proven fermentation technology that can be customized to meet specific requirements. The modular design allows optimal adaptation to different applications and organisms. Automated sterilization (SIP) and cleaning (CIP) processes ensure maximum convenience and efficiency. Scale-up and scale-down experiments are easy to perform thanks to the optimized system design.

Available as a stand-alone unit, in various configurations or as part of a production line with full FDA/EMA compliant documentation, the NLF is ideal for preclinical applications. The components are of high quality and durability, based on over 50 years of experience.



NLF fermenter as a stand-alone version.

- Individual configurations for different applications
- Different quality concepts for your documentation requirements
- Optimal system design for scale-up / scale-down

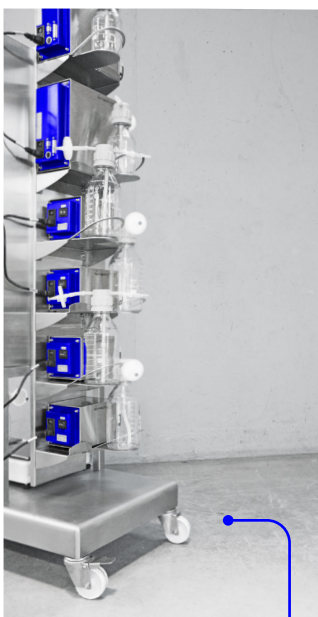

Space-saving and tidy storage of dosing pumps and laboratory bottles.

Technical Details

- Working volume: 11/13/20 liters
- Vessel: Stainless steel, double wall, also bottom area of vessel
- Drives: Top drive, bottom drive
- Stirrers: Rushton, propeller stirrers, pitched-blade stirrers, airlift, vibromixer, fixed bed
- Ventilation: Venting pipe, ring sparger, sinter sparger, surface gassing, bubble-free gassing
- Temperature circuit and sterilization: Electrical heating/cooling water, steam heating/cooling water
- Measurement and control technology: Speed, temperature, pH, pO₂, antifoam/level, redox, OD, weight, exhaust analysis, numerous additional interfaces and regulators
- Gas modules: Up to 8 individual gassing lines with pulsed valves or mass-flow controllers
- Dosing pumps: Up to 6 pumps. Interfaces for other pumps available.
- Cleaning: Manually / CIP
- BioSCADA: Sophisticated control and visualization software for data collection
- Several reactors can be operated via one computer / HMI

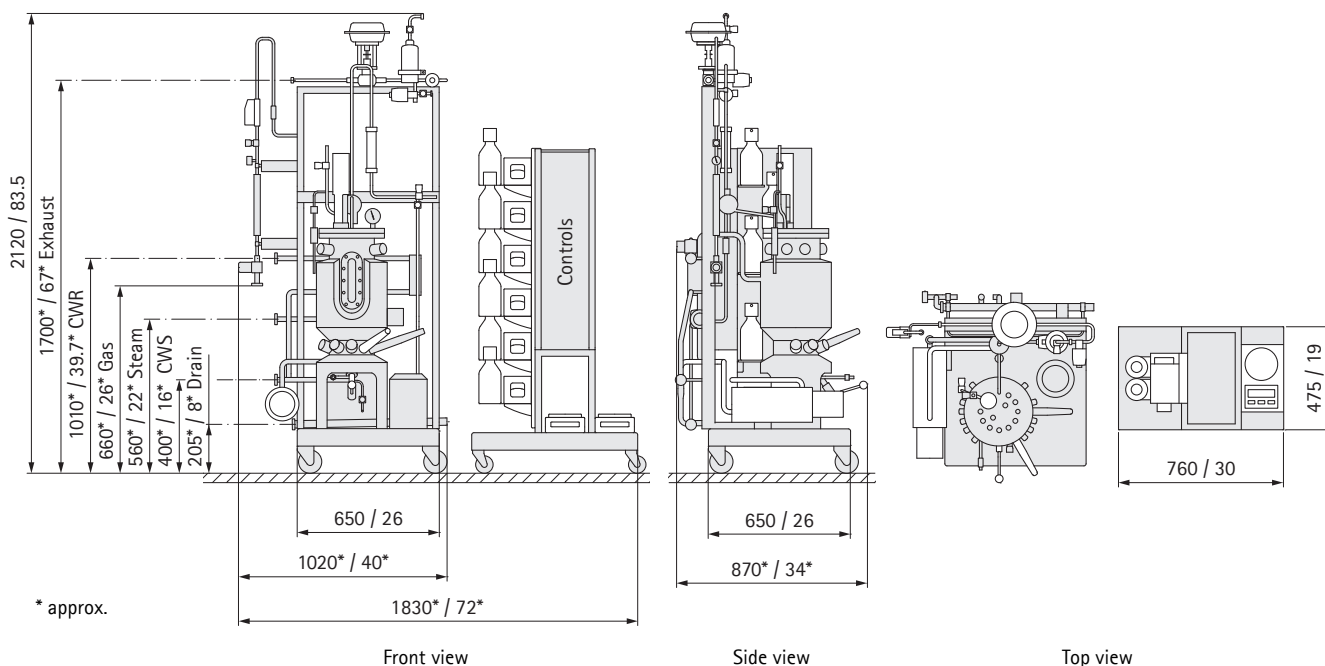

Dimensions are given in mm and inch and represent maximal values. Depending on fermentor configuration dimensions can be also smaller. White parts of drawing represent variable areas according to selected options.

Contact us for further information.

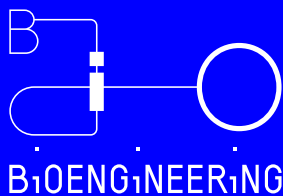

Bioengineering AG
Sagenrainstrasse 7, 8636 Wald, Switzerland
T +41 55 256 81 11
sales@bioengineering.ch

www.bioengineering.ch

Bioengineering – inspiring excellence

