



More information on the website
radwag.com/en/info,w1,APQ

AS 310.R2 PLUS Analytical Balance



The drawings, photos and graphics used are for illustrative purposes only.

Functions



Autotest



Dosing



Percent Weighing



Totalizing



Parts counting



Peak hold



Newton unit measurement



Statistics



Checkweighing



Under-pan weighing



GLP Procedures



Animal weighing



Density determination

Datasheet

Metrological parameters	
Maximum capacity [Max]	310 g
Minimum load	10 mg
Readability [d]	0,1 mg
Verification unit [e]	1 mg
Tare range	-310 g
Standard repeatability [5% Max]	0,08 mg

Metrological parameters	
Standard repeatability [Max]	0,12 mg
Standard minimum weight (USP)	160 mg
Standard minimum weight (U=1%, k=2)	16 mg
Permissible repeatability [5% Max]	0,12 mg
Permissible repeatability [Max]	0,15 mg
Linearity	±0,3 mg
Stabilization time	2,5 s
Adjustment	internal (automatic)
OIML Class	I
Physical parameters	
Leveling system	manual
Display	LCD (backlit)
Protection class	IP 43
Delivery components	Balance, weighing pan, weighing pan shield, bottom cover, power supply.
Weighing pan dimensions	ø100 mm
Packaging dimensions	495×400×515 mm
Net weight	7,3 kg
Gross weight	9,3 kg
Communication interface	
Communication interface	2×RS232 ¹ , 2×USB-A (interchangeable), USB-B, Wi-Fi (option)
Electrical parameters	
Power supply	Adapter: 100 – 240V AC 50/60Hz 0,6A; 12V DC 1,2A Balance: 12 – 15V DC 0,4A max
Power consumption max.	3 W
Environmental conditions	
Operating temperature	+10 ÷ +40 °C
Relative humidity	40% ÷ 80%

Repeatability is expressed as a standard deviation from 10 weighing cycles. Stabilization time depends on the ambient conditions and the dynamics of weighing pan loading; specified for FAST profile. 1 Barcode scanners, available as weighing instrument accessory, communicate with the instrument via RS232 interface exclusively.

* Wi-Fi® is a registered trademark of Wi-Fi® Alliance.



Extra payment for verification



Accessories

Holders for laboratory flasks

- UL-04-1 (AS) Laboratory Holders [WX-001-0033]
- UL-03-1 (AS) Laboratory Holders [WX-001-0032]

Power Adapters

- ZR-04/1 Powerbank [WX-015-0329]
- ZR-03/1 Powerbank [WX-015-0319]

Barcode scanners

Displays

- WD-6 LCD Display - Plastic Housing [WX-002-0030]

Protective cover for balances

- Protective Cover for X2 PLUS / R2 PLUS Balance [WX-001-0433]
- Fabric Dust Cover for AS PLUS Balances [WX-001-0179]

Weighing dishes

- Weighing dishes for ultra-microbalances, microbalances and

- PD9330-AR Barcode Scanner [WX-006-0030]
- PM9300-D Barcode Scanner [WX-006-0033]
- LS2208 Barcode Scanner [WX-006-0005]
- PD9530 Barcode Scanner [WX-006-0014]
- DS2208 Barcode Scanner [WX-006-0036]
- PM9300 Barcode Scanner [WX-006-0031]
- PM9300-DK Barcode Scanner [WX-006-0034]

Cigarette lighter receptacle power supply cables

- K0047 Car lighter 12V cable [WX-013-0034]

Density determination KIT

- KIT 85 Density Determination Kit [WX-001-0001]

USB cable (scale - printer)

- PT0238 USB Cable Type A-B [WX-013-0056]

Professional weighing table

- PSW Professional Single Weighing Workstation [WX-001-0020]
- PSW/DUAL Professional Dual Weighing Workstation [WX-001-0402]

Holders for test tubes and filters

- UL-02-1 (AS) Laboratory Holders [WX-001-0031]
- UL-01-1 (AS) Laboratory Holders [WX-001-0036]

Workstation for Pipettes Calibration

- SDKP Workstation for Pipettes Calibration [WL-101-0181]
- SDKP DUAL Workstation for Pipettes Calibration [WL-101-0173]

Antivibration Tables

- SAL/STONE/C Antivibration Table [WX-001-0078]

Software

- RAD Key [WX-010-0005]
- R-Panel [WX-010-0187]
- R-Lab [WX-010-0080]
- E2R Weighing Records [WX-010-0038]

analytical balances [WX-001-0429]

Antistatic ionizer

- DJ-04 Antistatic Ionizer [WX-001-0097]

Receipt Printer

- RTP-UEW80 Radwag Thermal Receipt Printer (USB + Ethernet + WiFi) [WX-007-0118]
- RTP-RU80 Radwag Thermal Receipt Printer (RS232 + USB) [WX-007-0119]

THBR 2.0 System - Ambient Conditions Monitoring

- RPanel BOX [WX-015-0216]

RS 232, RS 485 cables

- P0108 Cable [WX-013-0003]
- P0108.5 Cable [WX-013-0161]

Under-pan weighing

- Under-pan Weighing Rack for AS and PS Balances [WX-002-0111]
- Under-Pan Weighing Hook (XA, AS, PS) [WX-015-0325]

RS 232 cables (scale - printer)

- P0151 Cable [WX-013-0002]

Device dimensions

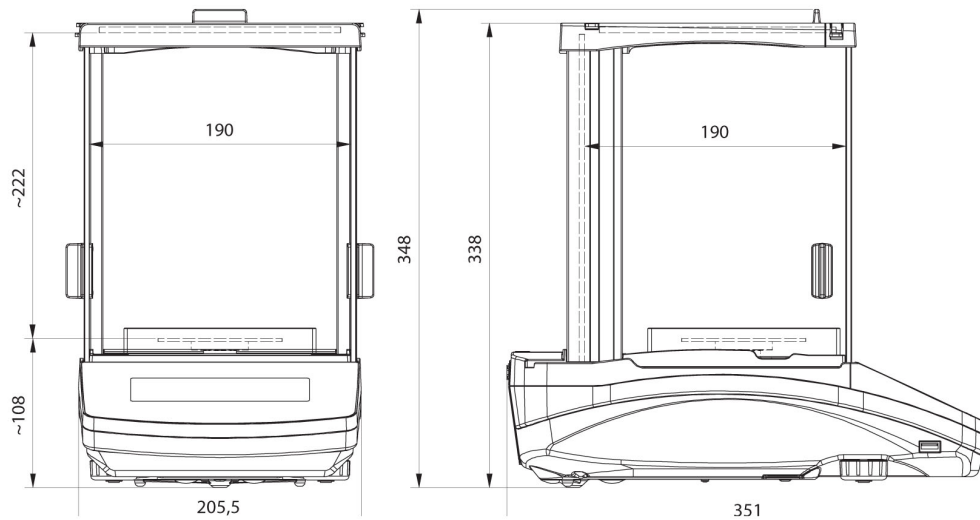

AS R2, d = 0.01 mg

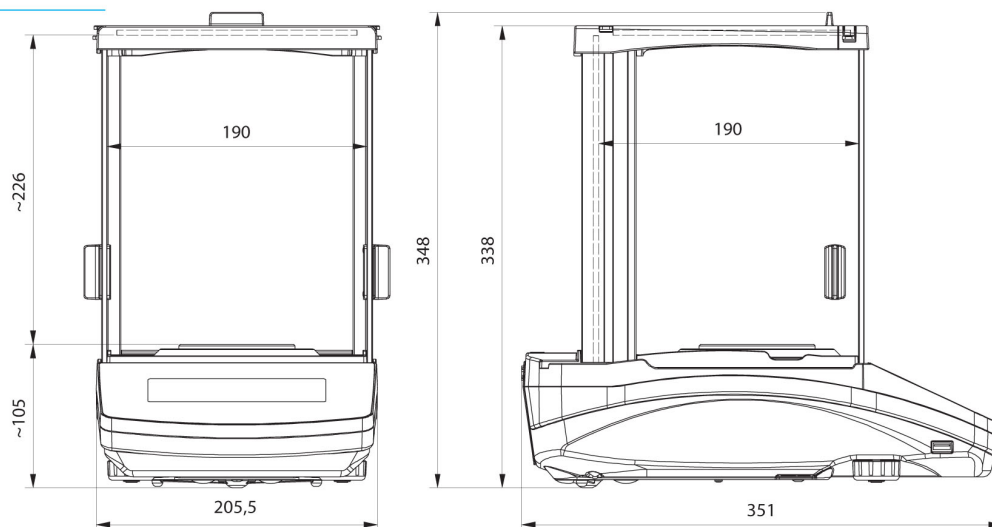

AS R2, AS R1 d = 0.1 mg