

DIAPHRAGM VACUUM PUMP N 860.3 FT.40.18

DATA SHEET E 278



Technical features

- Pure transferring and evacuation
- Highly compatible with vapors and condensation
- Integrated KNF self-drying system ensures that condensate is quickly removed from the pump heads without the vacuum being altered. This significantly reduces process time and preserves the pump heads.
- Chemically resistant and thus ideal for use with extremely aggressive/corrosive gases and vapors
- Environmentally friendly

Technical data

Flow rate [m ³ /h] at atm. pressure	3.6
Flow rate [l/min] at atm. pressure	60
Ultimate vacuum [mbar abs.]	4
Operating pressure [bar]	1
Voltage [V]	230
Frequencies [Hz]	50
Motor protection	IP 54
Power P ₁ [W]	220
Operating current [A]	1.6
With thermal switch and power fuse	
Motors with other voltages and frequencies on request	

MATERIALS

Pump head	PTFE
Diaphragm	PTFE-coated
Valves	FFPM

OTHER DATA

Weight [kg]	14.8
Hose connections	ID 12
Dimensions W x H x D [mm]	291 x 278 x 331
Permissible media and ambient temperature [°C]	+5 ... +40

ACCESSORIES

ACCESSORIES	ID
Spares kit	047499

Dimensions

N 860.3 FT.40.18

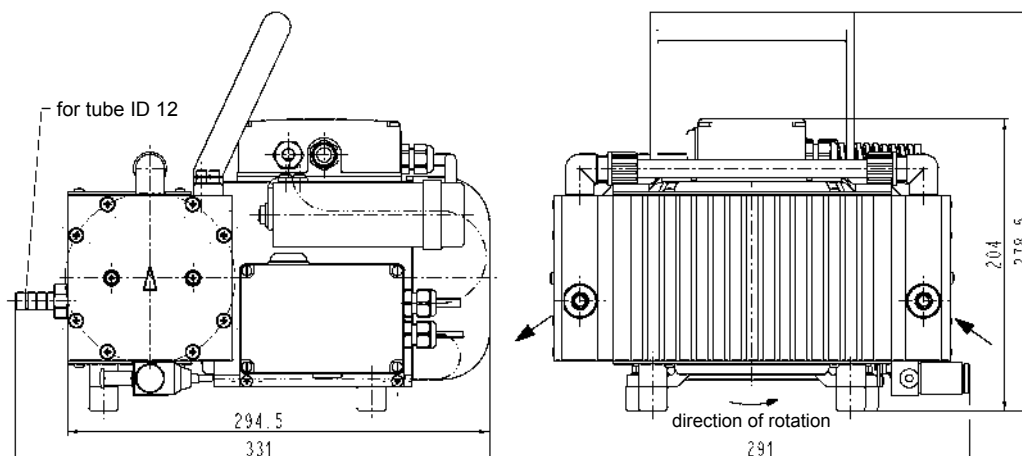

Performance characteristics

PUMP DOWN TIME FOR 20 LITER VESSEL

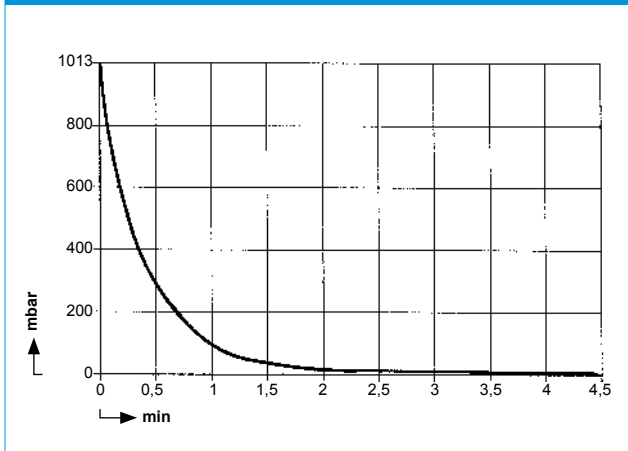

FLOW CAPACITY

