

# DIAPHRAGM VACUUM PUMP LABOPORT® N 816.1.2 KT.18



## Technical features

- 100 % oil-free transfer – thereby pure transferring, evacuation and compression of gases
- PTFE-coated diaphragm is ideal for aggressive/ corrosive gases and vapors
- Environmentally friendly
- High level of gas tightness

## Technical data

Flow rate [m³/h] at atm. pressure	1.8
Flow rate [l/min] at atm. pressure	30
Ultimate vacuum [mbar abs.]	160
Operating pressure [bar]	0.5
Voltage [V]	230
Frequencies [Hz]	50
Motor protection	IP 20
Power P <sub>1</sub> [W]	100
Operating current [A]	0.6
With thermal switch and power fuse	
Motors with other voltages and frequencies on request	

## MATERIALS

Pump head	PPS
Diaphragm	PTFE-coated
Valves	FFPM

## OTHER DATA

Weight [kg]	3.95
Hose connections	ID 6
Dimensions W x H x D [mm]	102 x 141 x 361
Permissible media and ambient temperature [°C]	+5 ... +40

## ACCESSORIES

	ID
Spares kit	056316

## Dimensions

N 816.1.2 KT.18

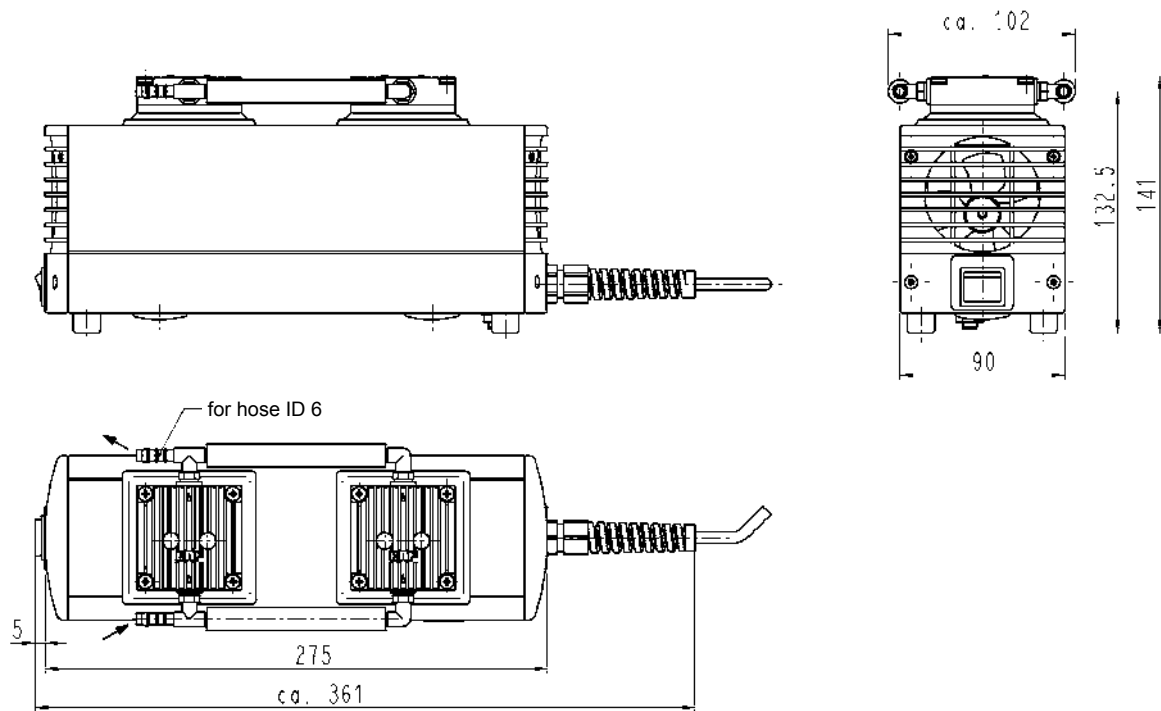

## Performance characteristics

PUMP DOWN TIME FOR 20 LITER VESSEL

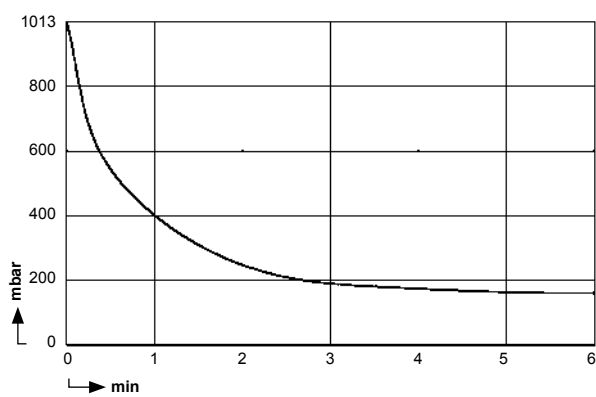

FLOW CAPACITY

