

# MARS PRO 900

## TECHNICAL DATA



### HIGHLIGHTS

- 3-filter design for maximum protection when handling hazardous materials such as cytostatic, virustatic pharmaceuticals substances.
- Compact Design enabling troublefree installation and relocation
- V-shaped table top
- Sloped front
- Excellent light distribution
- Electrical sliding front window
- Easy both side window cleaning

For more information please visit [www.labogene.com](http://www.labogene.com)

### Details

Product family	MARS PRO
Model:	900
Product type	Class II Biological Safety Cabinet according to EN 12469
Certificates	None
Compliance with	EN 12469, DIN 12980, EN 61010-1, EN 61000-6, EN11201
e-catalogue classification (UNSPSC code)	411035 Laminar flow cabinets or stations

General specifications	Unit		Note
Sound pressure level at factory settings	dB(A)	≤47	According to EN 11201
Sound pressure level in Eco-Save mode	dB(A)	≤37	Optional automatic mode shift available
Down flow, air velocity	m/s	0,28 ± 0,01	Factory setting according to EN 12469
Inflow, air velocity	m/s	0,45	Factory setting according to EN 12469
Exhaust, air flow rate	m³/h	292	Factory setting according to EN 12469
Light illuminance (flourescent tube)	Lux	> 1000	Optionale dimmable version available
Front opening (height)	mm	200	Factory setting (adjustable between 0-300mm)
Number of table top segments		3	Customized layout and accessories upon request
Filter construction in accordance with EN 1822-1		3-filter system, HEPA, at least Class U17	
Table top material		AISI 304 stainless steel	Optional AISI 316 stainless steel available
Table top max. total load	kg	100	
Side glass material		5 mm hardened glass w. 3 x ø22mm holes	Other hole options available
Front glass material		6mm laminated safety glass	Optional antireflex coating available
Cabinet and back wall material/colour		Polyester coated steel/RAL 9016	Other RAL colours available upon request

Dimensions	Unit		Note
External dimensions with adjustable stand (Std. height) (DxWxH)	mm	797 x 1004 x 2033	See drawing for details. Can pass through a standard door opening size 0,9x2,1M.
Table top height with adjustable stand (Std. height)	mm	750 (Range 745-780)	2 additional stand heights available as options
External dimensions with elec. elevation stand (DxWxH)	mm	797 x 1114 X 2025-2325	Available as an option. Please take note of the changing width of the cabinet.
Table top height with elec. elevation etand	mm	750-1050	
Work chamber dimensions (DxWxH)	mm	480x900x700	
Net weight	kg	296	
Shipping Volume	m³	ca. 2,2	

# MARS PRO 900

## TECHNICAL DATA

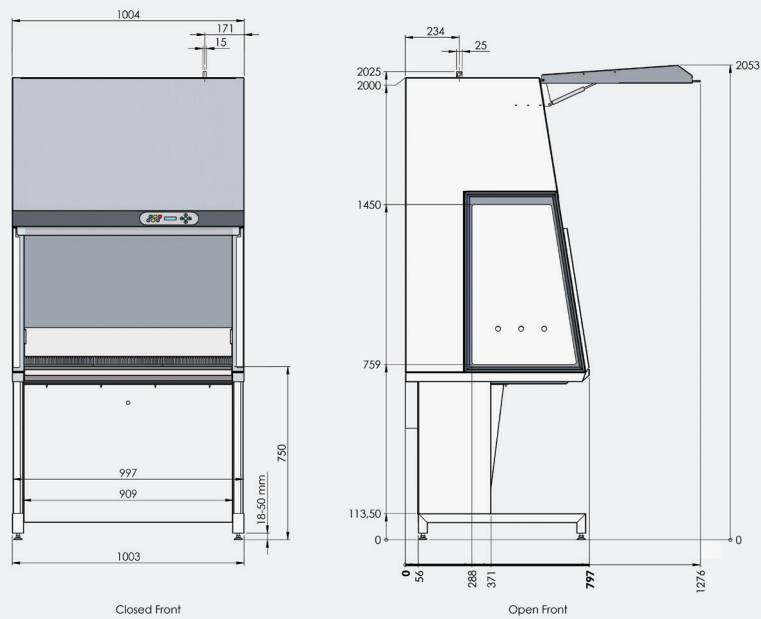

Electrical data	Unit		Note
Rated AC voltage/frequency	V/Hz	220-240/50-60	Other voltages available
Rated max. current (fuse)	A	10	
Power outlet(s) max. total current (fuse)	A	6,3	The sum of all power outlets
Type of power outlet socket, pair, left & right side		DK - type K (IP44)	Other types available. Select between 9 different regional types
Typical power consumption excl. power outlets	VA/Watt	87/80	With fluorescent dimmable light. At factory setting and normal operation
Typical power consumption excl. power outlets	VA/Watt	72/66	With LED dimmable light. At factory setting and normal operation
Typical power consumption in Eco-Save mode	VA/Watt	30/25	
Type of mains connection		3pin male type IEC320 C14	Top mounted, Left or right side

Additional available options	Unit		Note
Electrical elevation - Worktop height range	mm	745-1050	
UV-C sterilisation		Easy and fast decontamination	
Extra Power outlets, pair, left & right side		Select between 9 different regional types	
Antiblow back valve straight Ø 200 mm			
Antiblow back valve side Ø 200 mm			
Programmable output module for external control purposes		4 sets of potential free contacts	
Hydrogen Peroxide Vapour (VHP) Decontamination valves			

LaboGene ApS is Certified according to EN/ISO 9001 UKAS  
 LaboGene ApS owns the copyright of this data sheet. Subject to technical changes.  
 Illustrations may contain options and modifications not supplied as standard.

LaboGene ApS  
 Bjarkesvej 5  
 DK-3450 Allerød

Tel (+45) 3940 2566  
 Fax (+45) 3995 2566  
 Mail [info@labogene.com](mailto:info@labogene.com)  
 Web [www.labogene.com](http://www.labogene.com)

